

# VACdynamic 1.6



## CARACTÉRISTIQUES TECHNIQUES

|                                                |      |
|------------------------------------------------|------|
| Puissance (W)                                  | 1600 |
| Débit (m <sup>3</sup> /h)                      | 190  |
| Dépression (mm/H <sub>2</sub> O)               | 3100 |
| Airwatts                                       | 591  |
| Superficie filtre HEPA (cm <sup>2</sup> )      | 6000 |
| Superficie filtre PRO-TECTA (cm <sup>2</sup> ) | 1300 |
| Capacité bac (L)                               | 28   |
| Niveau sonore (dB)                             | ≤60  |
| Poids (kg)                                     | 15   |

Moteur grande vitesse by-pass périphérique

## RECOMMANDATIONS D'INSTALLATION

|                              |       |
|------------------------------|-------|
| M <sup>2</sup> logement      | ≤ 350 |
| Prise la plus lointaine (ml) | 30    |
| Nbre de prises               | 8     |

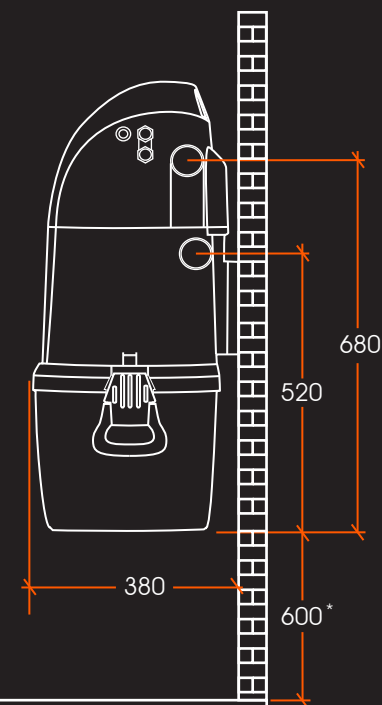
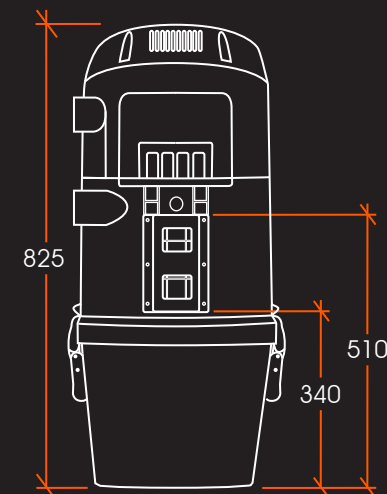

\* Distance minimum recommandée du sol pour faciliter la vidange de la cuve